

SWIFTSPACE | SHAPE

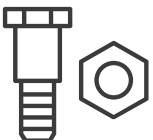

BENEFITS

Swiftspace is designed for flexibility, productivity, reducing costs, saving time and removing pain-points.



No loose parts to manage.

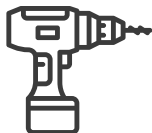

Minimal tools required.



No installers needed - it's DIY easy.



Reduce costs.



Installs in minutes, not hours



No punch list saves time.

Scope of Product

Shape is an **electric, height adjustable solution that come in a straight single configuration or as an L-Shaped dual worksurface***. It is mobile with caster that swivel and lock and is available in various combinations of worksurface lengths. Surfaces flip up on singles and additionally, folds on dual surfaces for easy storage.

Breadth of Offering

- Shape comes in standard lengths of 46" (1168mm), 58" (1473mm), and 70" (1778mm). Custom lengths are available.
- Standard depth is 24" (610mm) or 30" (762mm).
- Worksurfaces can be height adjustable with a range 21.9"-48.1"(556mm - 1222mm) powered by a bluetooth-compatible controller or can be fixed height (set at 29"H (737mm) standard or custom height if requested).
- Worksurfaces can be finished in high pressure laminate or whiteboard.
- Accessories include but are not limited to; mounted accessory rails with paper trays, pen holders and binder holders and monitor arms.
- For added privacy, HPL Surround panels can be attached and/or privacy and modesty panels can be added to the back and sides of Shape
- Storage options include freestanding pedestals, and towers.
- **Single Surface stations can be modified to Dual Surface L-Shape with the addition of a second surface**
- Shape legs come standard in White or Silver

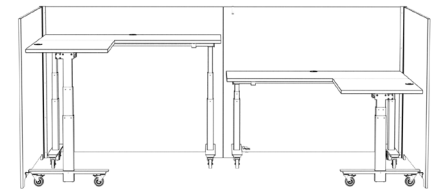

System Engineering

- Shape is **equipped with heavy-duty steel ball bearing casters with rubber wheels that are designed to go over thresholds, dockplates and other rough terrain without damage***.
- **Shape with a single worksurface can fold vertically to an overall size of 23"D (584mm). This is done by pulling a lever mounted under the surface and lifting the surface***. This allows for easy storage and nesting with other like tables.
- **Dual surface Shapes can be folded to an overall depth of 27"(686mm)***. This is done by removing the thumbscrews on the locking plates under the surface, lifting the main surface and then the return surface and then be rotated and folded to meet the main surface.
- Shape stations are **engineered to be completely set-up in minutes without the use of any tools, additional hardware, parts or pieces. It can be setup and then folded down many times without loss of functionality***.
- Stations can be fixed in place using a castor lock or linking plate to link to next station. Locks can only be removed with a screwdriver. Locking Bracket available to prevent castor locking tab from becoming disengaged. Available upon request at no additional cost. 2 locks/station.

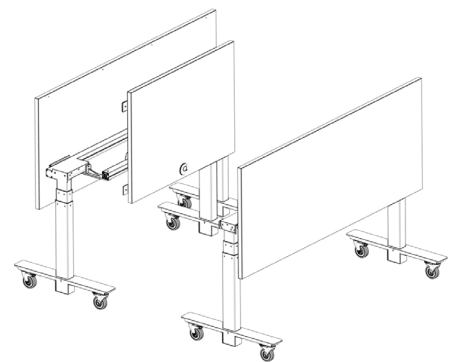

Construction

- Worksurfaces are 1" (25.4mm) thick high pressure laminate with a 45lb density particleboard core, 0.08" (2mm) edging. Options for powdercoated, thermoformed, and solid surface available upon request.
- Castors are 2.5" (64mm) in diameter with grey non-marking rubber wheels that swivel and lock.
- Shape legs are a compact three-part lifting column. The three-part construction ensures a short installation dimension combined with a long stroke length. Legs come standard in white or silver. Other colours are available to fit into a wide range of desk designs.
- Surround panels are 3/4" (19mm) thick high pressure laminate with a 45lb density particleboard core, 0.08" (2mm) edging.
- **Shape is equipped with a control box. Standard controls include a programmable paddle switch with digital display and bluetooth*.**

Installation and Warranty

- Can be installed or serviced directly by the user or any common furniture installer and not violate or void any product warranty. Installation will not require any tools or professional training.
- Station **ships fully assembled on casters; the entire station will be one unit with no separate pieces,*** except for any mobile storage or some accessories that are to be attached after installation.
- For product warranty please see Conditions of Sale, Return Policy, and Warranty in the Specification and Price Guide.
- **Non Height Adjust stations can be upgraded to Height Adjustable in the field with our add-on kit**

Electrical

- A power/data rail can be added to the base. The raceway has 2 channels; the top channel is used to run power cables or hardwired power while the bottom (metallically separated from the top) can support up to 40 CAT6 data cables or phone lines.
- Optional power bars include a module with 6 electrical outlets, 4 USB ports and 15 ft power cord or a surface-mounted module equipped with 2 electrical plugs, 2 USB ports and 1 data port.
- When Dual Surface Shape is ordered with Surround Privacy Panels, power/data rails are mounted to the panels which can have cut-outs for daisy chaining.
- For longer runs, a 4-circuit 80 amp quick connect/disconnect power system can be added in the (optional) Power and Data trough. Separate compartment for running up to 40 data cables.
- **Battery packs available for cordless operation of the station.** At full charge with a 1/2 load weight (125lbs) on the worksurface the battery will move the SHAPE worksurface all the way up and down approx. 35 times.

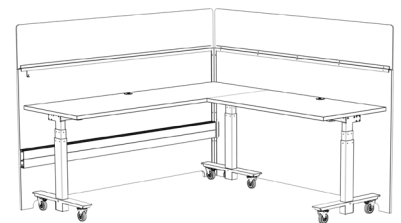
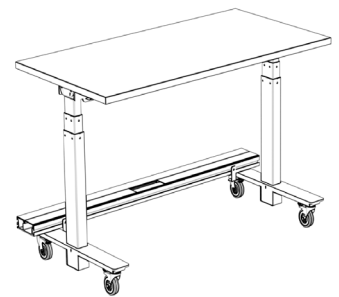

**Key Product Features*

***All Swiftspace workstations have been tested and meet ANSI/BIFMA standards.*